

Series **GEFH1/3**



SET ~ 3

रोल नं.

Roll No.



प्रश्न-पत्र कोड
Q.P. Code

55/3/3

परीक्षार्थी प्रश्न-पत्र कोड को उत्तर-पुस्तिका के मुख-पृष्ठ पर अवश्य लिखें ।

Candidates must write the Q.P. Code on the title page of the answer-book. *

भौतिक विज्ञान (सैद्धान्तिक) PHYSICS (Theory)

निर्धारित समय : 3 घण्टे

अधिकतम अंक : 70

Time allowed : 3 hours

Maximum Marks : 70

नोट / NOTE :

- (i) कृपया जाँच कर लें कि इस प्रश्न-पत्र में मुद्रित पृष्ठ **23** हैं ।
Please check that this question paper contains **23** printed pages.
- (ii) प्रश्न-पत्र में दाहिने हाथ की ओर दिए गए प्रश्न-पत्र कोड को परीक्षार्थी उत्तर-पुस्तिका के मुख-पृष्ठ पर लिखें ।
Q.P. Code given on the right hand side of the question paper should be written on the title page of the answer-book by the candidate.
- (iii) कृपया जाँच कर लें कि इस प्रश्न-पत्र में **35** प्रश्न हैं ।
Please check that this question paper contains **35** questions.
- (iv) कृपया प्रश्न का उत्तर लिखना शुरू करने से पहले, उत्तर-पुस्तिका में प्रश्न का क्रमांक अवश्य लिखें ।
Please write down the serial number of the question in the answer-book before attempting it.
- (v) इस प्रश्न-पत्र को पढ़ने के लिए 15 मिनट का समय दिया गया है । प्रश्न-पत्र का वितरण पूर्वाह्न में 10.15 बजे किया जाएगा । 10.15 बजे से 10.30 बजे तक छात्र केवल प्रश्न-पत्र को पढ़ेंगे और इस अवधि के दौरान वे उत्तर-पुस्तिका पर कोई उत्तर नहीं लिखेंगे ।
15 minute time has been allotted to read this question paper. The question paper will be distributed at 10.15 a.m. From 10.15 a.m. to 10.30 a.m., the students will read the question paper only and will not write any answer on the answer-book during this period.



सामान्य निर्देश:

निम्नलिखित निर्देशों को बहुत सावधानी से पढ़िए और उनका सख्ती से पालन कीजिए :

- (i) इस प्रश्न-पत्र में 35 प्रश्न हैं। सभी प्रश्न अनिवार्य हैं।
- (ii) यह प्रश्न-पत्र पाँच खण्डों में विभाजित है – क, ख, ग, घ एवं ङ।
- (iii) खण्ड क में प्रश्न संख्या 1 से 18 तक बहुविकल्पीय (MCQ) प्रकार के एक-एक अंक के प्रश्न हैं।
- (iv) खण्ड ख में प्रश्न संख्या 19 से 25 तक अति लघु-उत्तरीय (VSA) प्रकार के दो-दो अंकों के प्रश्न हैं।
- (v) खण्ड ग में प्रश्न संख्या 26 से 30 तक लघु-उत्तरीय (SA) प्रकार के तीन-तीन अंकों के प्रश्न हैं।
- (vi) खण्ड घ में प्रश्न संख्या 31 से 33 तक दीर्घ-उत्तरीय (LA) प्रकार के पाँच-पाँच अंकों के प्रश्न हैं।
- (vii) खण्ड ङ में प्रश्न संख्या 34 तथा 35 केस-आधारित चार-चार अंकों के प्रश्न हैं।
- (viii) प्रश्न-पत्र में समग्र विकल्प नहीं दिया गया है। यद्यपि, खण्ड ख के 2 प्रश्नों में, खण्ड ग के 2 प्रश्नों में, खण्ड घ के 3 प्रश्नों में तथा खण्ड ङ के 2 प्रश्नों में आंतरिक विकल्प का प्रावधान दिया गया है।
- (ix) कैल्कुलेटर का उपयोग वर्जित है।

भौतिक नियतांकों के निम्नलिखित मान, आवश्यकता अनुसार उपयोग करें :

$$c = 3 \times 10^8 \text{ m/s}$$

$$h = 6.63 \times 10^{-34} \text{ Js}$$

$$e = 1.6 \times 10^{-19} \text{ C}$$

$$\mu_0 = 4\pi \times 10^{-7} \text{ T m A}^{-1}$$

$$\epsilon_0 = 8.854 \times 10^{-12} \text{ C}^2 \text{ N}^{-1} \text{ m}^{-2}$$

$$\frac{1}{4\pi\epsilon_0} = 9 \times 10^9 \text{ N m}^2 \text{ C}^{-2}$$

$$\text{इलेक्ट्रॉन का द्रव्यमान (} m_e \text{)} = 9.1 \times 10^{-31} \text{ kg}$$

$$\text{न्यूट्रॉन का द्रव्यमान} = 1.675 \times 10^{-27} \text{ kg}$$

$$\text{प्रोटॉन का द्रव्यमान} = 1.673 \times 10^{-27} \text{ kg}$$

$$\text{आवोगाद्रो संख्या} = 6.023 \times 10^{23} \text{ प्रति ग्राम मोल (per gram mole)}$$

$$\text{बोल्ट्ज़मान नियतांक} = 1.38 \times 10^{-23} \text{ JK}^{-1}$$





General Instructions :

Read the following instructions very carefully and strictly follow them :

- (i) This question paper contains **35** questions. **All** questions are **compulsory**.
- (ii) This question paper is divided into **five** Sections – **A, B, C, D** and **E**.
- (iii) In **Section A** – Questions no. **1** to **18** are Multiple Choice (MCQ) type questions, carrying **1** mark each.
- (iv) In **Section B** – Questions no. **19** to **25** are Very Short Answer (VSA) type questions, carrying **2** marks each.
- (v) In **Section C** – Questions no. **26** to **30** are Short Answer (SA) type questions, carrying **3** marks each.
- (vi) In **Section D** – Questions no. **31** to **33** are Long Answer (LA) type questions carrying **5** marks each.
- (vii) In **Section E** – Questions no. **34** and **35** are case-based questions carrying **4** marks each.
- (viii) There is no overall choice. However, an internal choice has been provided in 2 questions in Section B, 2 questions in Section C, 3 questions in Section D and 2 questions in Section E.
- (ix) Use of calculators is **not** allowed.

Use the following values of physical constants, if required :

$$c = 3 \times 10^8 \text{ m/s}$$

$$h = 6.63 \times 10^{-34} \text{ Js}$$

$$e = 1.6 \times 10^{-19} \text{ C}$$

$$\mu_0 = 4\pi \times 10^{-7} \text{ T m A}^{-1}$$

$$\epsilon_0 = 8.854 \times 10^{-12} \text{ C}^2 \text{ N}^{-1} \text{ m}^{-2}$$

$$\frac{1}{4\pi\epsilon_0} = 9 \times 10^9 \text{ N m}^2 \text{ C}^{-2}$$

$$\text{Mass of electron } (m_e) = 9.1 \times 10^{-31} \text{ kg}$$

$$\text{Mass of neutron} = 1.675 \times 10^{-27} \text{ kg}$$

$$\text{Mass of proton} = 1.673 \times 10^{-27} \text{ kg}$$

$$\text{Avogadro's number} = 6.023 \times 10^{23} \text{ per gram mole}$$

$$\text{Boltzmann constant} = 1.38 \times 10^{-23} \text{ JK}^{-1}$$





खण्ड क

1. किसी बाह्य परिपथ से वि.वा. बल (emf) E और आंतरिक प्रतिरोध r की कोई बैटरी संयोजित है। बैटरी के भीतर विभव पात किसके अनुपाती है ?
 - (a) परिपथ में धारा
 - (b) परिपथ का कुल प्रतिरोध
 - (c) बैटरी का वि.वा. बल (emf)
 - (d) परिपथ में शक्ति क्षय
2. तरंगदैर्घ्य λ के किसी फोटॉन का संवेग होता है :
 - (a) $\frac{h\lambda}{c^2}$
 - (b) $\frac{h\lambda}{c}$
 - (c) $\frac{h}{\lambda}$
 - (d) शून्य
3. दूरी r के पृथक्कन वाले दो पतले लम्बे समान्तर तारों A और B से समान दिशा में प्रत्येक से धारा I प्रवाहित हो रही है। तार A द्वारा तार B पर आरोपित बल प्रति एकांक लम्बाई है :
 - (a) $\frac{\mu_0 I^2}{2r}$, आकर्षी
 - (b) $\frac{\mu_0 I^2}{2\pi r}$, प्रतिकर्षी
 - (c) $\frac{\mu_0 I^2}{2\pi r}$, आकर्षी
 - (d) $\frac{\mu_0 I^2}{2\pi r}$, प्रतिकर्षी
4. समान लम्बाई के दो तार जिनकी त्रिज्याएँ r और $2r$ हैं, श्रेणी में संयोजित हैं। इनकी प्रतिरोधकताएँ क्रमशः 2ρ और ρ हैं। इस संयोजन से प्रवाहित समान धारा के लिए, इन तारों के सिरों पर विभव पातों का अनुपात होगा :
 - (a) 2 : 1
 - (b) 1 : 2
 - (c) 4 : 1
 - (d) 8 : 1
5. किसी संधारित्र को किसी बैटरी द्वारा आवेशित किया गया है। आवेशित करते समय संधारित्र की पट्टिकाओं के बीच
 - (a) केवल विस्थापन धारा विद्यमान होती है।
 - (b) केवल चालन धारा विद्यमान होती है।
 - (c) विस्थापन धारा और चालन धारा दोनों विद्यमान रहती हैं।
 - (d) कोई धारा विद्यमान नहीं रहती है।





SECTION A

1. A battery of emf E and internal resistance r is connected to an external circuit. The potential drop within the battery is proportional to :
- (a) current in the circuit
 - (b) total resistance of the circuit
 - (c) emf of the battery
 - (d) power dissipated in the circuit
2. The momentum of a photon of wavelength λ is :
- (a) $\frac{h\lambda}{c^2}$
 - (b) $\frac{h\lambda}{c}$
 - (c) $\frac{h}{\lambda}$
 - (d) zero
3. Two thin long parallel wires A and B are separated by a distance r and carry current I each in the same direction. The force per unit length exerted by A on wire B is :
- (a) $\frac{\mu_0 I}{2r}$, attractive
 - (b) $\frac{\mu_0 I^2}{2\pi r}$, repulsive
 - (c) $\frac{\mu_0 I^2}{2\pi r}$, attractive
 - (d) $\frac{\mu_0 I}{2\pi r}$, repulsive
4. Two wires of equal length and radii r and $2r$ are connected in series. Their resistivities are 2ρ and ρ respectively. For the same current passing through the combination, the potential drop across their ends will be in the ratio of :
- (a) 2 : 1
 - (b) 1 : 2
 - (c) 4 : 1
 - (d) 8 : 1
5. A capacitor is charged by a battery. Between the plates, during process of charging :
- (a) only displacement current exists.
 - (b) only conduction current exists.
 - (c) both displacement current and conduction current exist.
 - (d) no current exists.





6. प्रकाश के तरंग चित्रण में, प्रकाश की तीव्रता I और तरंग के आयाम A के बीच के संबंध को इस प्रकार दर्शाया जाता है :

- (a) $I \propto \sqrt{A}$
- (b) $I \propto A$
- (c) $I \propto A^2$
- (d) $I \propto \frac{1}{A^2}$

7. किसी p-n संधि डायोड के अग्रदिशिक बायसन के लिए निम्नलिखित में से कौन-सा कथन सही नहीं है ?

- (a) रोधिका विभव घट जाता है ।
- (b) अल्पांश वाहक अंतःक्षेपण होता है ।
- (c) हासी स्तर की चौड़ाई बढ़ जाती है ।
- (d) अग्रदिशिक धारा विवरों और इलेक्ट्रॉनों दोनों के विसरण के कारण होती है ।

8. निम्नलिखित में से कौन-सा ग्राफ किसी त्रिज्या 'a' के अनन्त लम्बाई के धारावाही सीधे तार के केन्द्र से दूरी 'r' को फलन मानकर उसके बाहर के चुम्बकीय क्षेत्र के परिमाण के विचरण का सही निरूपण करता है ?

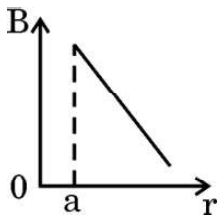

(a)

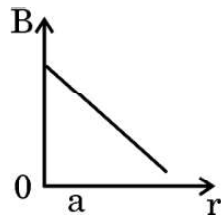

(b)

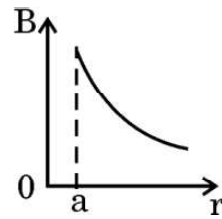

(c)

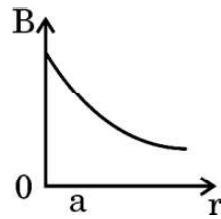

(d)

9. कार्य फलन 2.14 eV की किसी धातु पर आवृत्ति $6.4 \times 10^{14} \text{ Hz}$ का प्रकाश आपतन कर रहा है । उत्सर्जित इलेक्ट्रॉनों की अधिकतम गतिज ऊर्जा होगी लगभग :

- (a) 0.25 eV
- (b) 0.51 eV
- (c) 1.02 eV
- (d) 0.10 eV



6. In the wave picture of light, the intensity I of light is related to the amplitude A of the wave as :

- (a) $I \propto \sqrt{A}$
- (b) $I \propto A$
- (c) $I \propto A^2$
- (d) $I \propto \frac{1}{A^2}$

7. For the forward biasing of a p-n junction diode, which of the following statements is **not** correct ?

- (a) The potential barrier decreases.
- (b) Minority carrier injection occurs.
- (c) Width of depletion layer increases.
- (d) Forward current is due to the diffusion of both holes and electrons.

8. Which of the following graphs correctly represents the variation of the magnitude of the magnetic field outside a straight infinite current carrying wire of radius 'a', as a function of distance 'r' from the centre of the wire ?

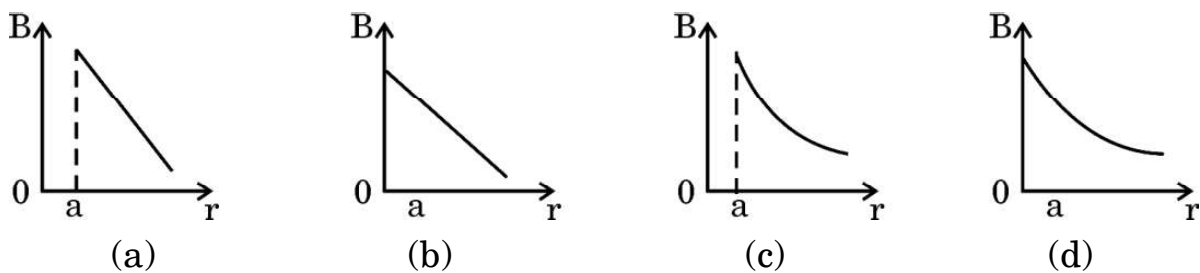

9. Light of frequency 6.4×10^{14} Hz is incident on a metal of work function 2.14 eV. The maximum kinetic energy of the emitted electrons is about :

- (a) 0.25 eV
- (b) 0.51 eV
- (c) 1.02 eV
- (d) 0.10 eV





10. किसी वोल्टता सिग्नल का किसी चक्र के लिए वर्णन इस प्रकार किया गया है :

$$v = V_0 \quad 0 \leq t \leq \frac{T}{2} \text{ के लिए}$$

$$= 0 \quad \frac{T}{2} \leq t \leq T \text{ के लिए}$$

इसका rms मान है :

(a) $\frac{V_0}{\sqrt{2}}$

(b) V_0

(c) $\frac{V_0}{2}$

(d) $\sqrt{2} V_0$

11. किसी नैज अर्धचालक में किसी निश्चित ताप पर इलेक्ट्रॉनों और विवरों की सांद्रता $1.5 \times 10^{16} \text{ m}^{-3}$ है। जब इसे त्रिसंयोजक अपमिश्रक से मादित किया जाता है, तो विवर सांद्रता बढ़कर $4.5 \times 10^{22} \text{ m}^{-3}$ हो जाती है। मादित अर्धचालक में इलेक्ट्रॉनों की सांद्रता (n_e) होगी :

(a) $3 \times 10^6 \text{ m}^{-3}$

(b) $5 \times 10^7 \text{ m}^{-3}$

(c) $5 \times 10^9 \text{ m}^{-3}$

(d) $6.75 \times 10^{38} \text{ m}^{-3}$

12. किसी एकल-झिरी विवर्तन प्रयोग में, झिरी की चौड़ाई आधी कर दी जाती है। विवर्तन पैटर्न में केंद्रीय उच्चिष्ठ की चौड़ाई हो जाएगी :

(a) आधी

(b) दुगुनी

(c) चार गुनी

(d) एक-चौथाई

13. बोर के मॉडल में हाइड्रोजन के स्पेक्ट्रम की बामर श्रेणी में उत्सर्जित प्रकाश की अधिकतम आवृत्ति और निम्नतम आवृत्ति का अनुपात होता है :

(a) $\frac{11}{9}$

(b) $\frac{9}{5}$

(c) $\frac{11}{7}$

(d) $\frac{16}{7}$





10. A voltage signal is described by :

$$v = V_0 \quad \text{for } 0 \leq t \leq \frac{T}{2}$$
$$= 0 \quad \text{for } \frac{T}{2} \leq t \leq T$$

for a cycle. Its rms value is :

(a) $\frac{V_0}{\sqrt{2}}$

(b) V_0

(c) $\frac{V_0}{2}$

(d) $\sqrt{2} V_0$

11. At a certain temperature in an intrinsic semiconductor, the electrons and holes concentration is $1.5 \times 10^{16} \text{ m}^{-3}$. When it is doped with a trivalent dopant, hole concentration increases to $4.5 \times 10^{22} \text{ m}^{-3}$. In the doped semiconductor, the concentration of electrons (n_e) will be :

(a) $3 \times 10^6 \text{ m}^{-3}$

(b) $5 \times 10^7 \text{ m}^{-3}$

(c) $5 \times 10^9 \text{ m}^{-3}$

(d) $6.75 \times 10^{38} \text{ m}^{-3}$

12. In a single-slit diffraction experiment, the width of the slit is halved. The width of the central maximum, in the diffraction pattern, will become :

(a) half

(b) twice

(c) four times

(d) one-fourth

13. The ratio of maximum frequency and minimum frequency of light emitted in Balmer series of hydrogen spectrum, in Bohr's model is :

(a) $\frac{11}{9}$

(b) $\frac{9}{5}$

(c) $\frac{11}{7}$

(d) $\frac{16}{7}$





14. दो सेलों, जिनमें प्रत्येक का वि.वा. बल (emf) E और आंतरिक प्रतिरोध r और $2r$ है, आरेख में दर्शाए अनुसार पार्श्व में संयोजित हैं। इस संयोजन का समतुल्य वि.वा. बल (emf) है :

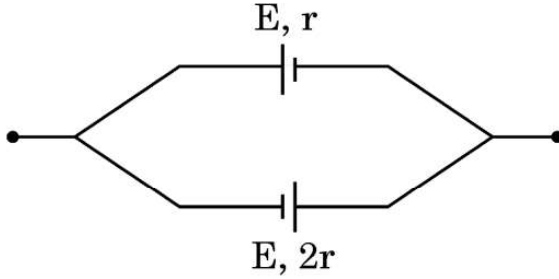

- (a) शून्य (b) $\frac{E}{2}$
(c) $\frac{E}{3}$ (d) E
15. कोई प्रेरक, कोई संधारित्र और कोई प्रतिरोधक श्रेणी में किसी ac वोल्टता स्रोत के सिरों से संयोजित हैं। यदि स्रोत की आवृत्ति को धीरे-धीरे घटाया जाए, तो :
- (a) प्रेरक और संधारित्र दोनों के प्रतिघात घटते हैं।
(b) प्रेरक का प्रतिघात घटता है और संधारित्र का प्रतिघात बढ़ता है।
(c) प्रेरक और संधारित्र दोनों के प्रतिघात बढ़ते हैं।
(d) प्रेरक का प्रतिघात बढ़ता है और संधारित्र का प्रतिघात घटता है।

प्रश्न संख्या 16 से 18 अभिकथन (A) और कारण (R) प्रकार के प्रश्न हैं। दो कथन दिए गए हैं — जिनमें एक को अभिकथन (A) तथा दूसरे को कारण (R) द्वारा अंकित किया गया है। सही उत्तर नीचे दिए गए कोडों (a), (b), (c) और (d) में से चुनकर दीजिए।

- (a) अभिकथन (A) और कारण (R) दोनों सही हैं और कारण (R), अभिकथन (A) की सही व्याख्या करता है।
(b) अभिकथन (A) और कारण (R) दोनों सही हैं, परन्तु कारण (R), अभिकथन (A) की सही व्याख्या नहीं करता है।
(c) अभिकथन (A) सही है, परन्तु कारण (R) ग़लत है।
(d) अभिकथन (A) ग़लत है और कारण (R) भी ग़लत है।
16. अभिकथन (A) : नाभिक ${}^4_3\text{Y}$ की अपेक्षा नाभिक ${}^7_3\text{X}$ अधिक स्थायी है।

कारण (R) : ${}^7_3\text{X}$ में प्रोटॉनों की संख्या अधिक है।





14. Two cells of emf E each and internal resistances r and $2r$ are connected in parallel as shown in the figure. The equivalent emf of the combination is :

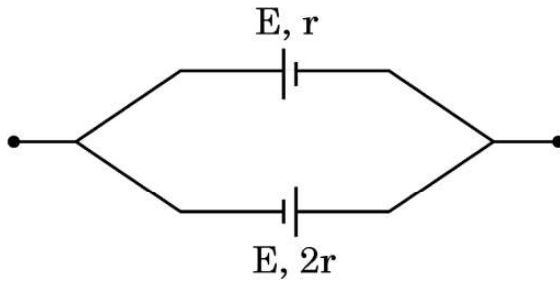

- (a) zero (b) $\frac{E}{2}$
(c) $\frac{E}{3}$ (d) E
15. An inductor, a capacitor and a resistor are connected in series across an ac source of voltage. If the frequency of the source is decreased gradually, the reactance of :
- (a) both the inductor and the capacitor decreases.
(b) inductor decreases and the capacitor increases.
(c) both the inductor and the capacitor increases.
(d) inductor increases and the capacitor decreases.

Questions number 16 to 18 are Assertion (A) and Reason (R) type questions. Two statements are given — one labelled Assertion (A) and the other labelled Reason (R). Select the correct answer from the codes (a), (b), (c) and (d) as given below.

- (a) Both Assertion (A) and Reason (R) are true and Reason (R) is the correct explanation of the Assertion (A).
(b) Both Assertion (A) and Reason (R) are true, but Reason (R) is **not** the correct explanation of the Assertion (A).
(c) Assertion (A) is true, but Reason (R) is false.
(d) Assertion (A) is false and Reason (R) is also false.

16. Assertion (A): The nucleus ${}^7_3\text{X}$ is more stable than the nucleus ${}^4_3\text{Y}$.

Reason (R): ${}^7_3\text{X}$ contains more number of protons.



17. **अभिकथन (A) :** किसी सेल का आन्तरिक प्रतिरोध नियत रहता है ।
कारण (R) : उपयोग करते समय सेल के विद्युत-अपघट्य की आयनी सांद्रता समान रहती है ।
18. **अभिकथन (A) :** जब किसी वृत्ताकार पाश, जिससे कोई स्थायी धारा प्रवाहित हो रही है, की त्रिज्या दुगुनी की जाती है, तो उसका चुम्बकीय आघूर्ण चार गुना हो जाता है ।
कारण (R) : किसी वृत्ताकार पाश, जिससे कोई स्थायी धारा प्रवाहित हो रही है, का चुम्बकीय आघूर्ण उस पाश के क्षेत्रफल के समानुपाती होता है ।

खण्ड ख

19. किसी p-n संधि के उस गुण की व्याख्या कीजिए जो इसे प्रत्यावर्ती वोल्टताओं के दिष्टकरण के लिए उपयुक्त बनाता है । पूर्ण-तरंग दिष्टकारी और अर्ध-तरंग दिष्टकारी के बीच विभेदन कीजिए । 2
20. (क) द्रव्यमान संख्या A को फलन मानकर बंधन ऊर्जा प्रति न्यूक्लिऑन के विचरण को दर्शाने वाला ग्राफ खींचिए । भारी नाभिकों ($A > 170$) के लिए द्रव्यमान संख्या में वृद्धि होने पर बंधन ऊर्जा प्रति न्यूक्लिऑन घटती है । व्याख्या कीजिए । 2
- अथवा**
- (ख) बोर अभिगृहीतों का उपयोग करते हुए, हाइड्रोजन परमाणु में n वीं स्थाई कक्षा की त्रिज्या का व्यंजक प्राप्त कीजिए । 2
21. 'विस्थापन धारा' से क्या तात्पर्य है ? संक्षेप में व्याख्या कीजिए कि यह धारा चालन धारा से किस प्रकार भिन्न है । 2
22. लम्बाई L के किसी तार को (i) वर्ग के रूप में, और फिर (ii) समबाहु त्रिभुज के रूप में मोड़ा गया है । यदि दोनों तारों से समान धारा I प्रवाहित की जाती है, तो वर्ग पाश के चुम्बकीय आघूर्ण से त्रिभुज के चुम्बकीय आघूर्ण का अनुपात ज्ञात कीजिए । 2
23. (क) हाइगेन्स सिद्धान्त लिखिए । हाइगेन्स ने पश्च तरंग की अनुपस्थिति की व्याख्या किस प्रकार की ? 2
- अथवा**
- (ख) हाइगेन्स सिद्धान्त का उपयोग करके (i) अवतल दर्पण, तथा (ii) उत्तल लेंस द्वारा किसी समतल तरंग का परावर्तन/अपवर्तन दर्शाइए । 2





17. *Assertion (A)* : The internal resistance of a cell is constant.
Reason (R) : Ionic concentration of the electrolyte remains same during use of a cell.
18. *Assertion (A)* : When radius of a circular loop carrying a steady current is doubled, its magnetic moment becomes four times.
Reason (R): The magnetic moment of a circular loop carrying a steady current is proportional to the area of the loop.

SECTION B

19. Explain the property of a p-n junction which makes it suitable for rectifying alternating voltages. Differentiate between a half-wave and a full-wave rectifier. 2
20. (a) Draw a graph showing the variation of binding energy per nucleon as a function of mass number A . The binding energy per nucleon for heavy nuclei ($A > 170$) decreases with the increase in mass number. Explain. 2

OR

- (b) Using Bohr's postulates, obtain the expression for radius of n^{th} stable orbit in a hydrogen atom. 2
21. What is meant by the term 'displacement current' ? Briefly explain how this current is different from a conduction current. 2
22. A wire of length L is bent round in the form of (i) a square, and then (ii) an equilateral triangle. If current I is passed through each of them, find the ratio of magnetic moment of the square loop to that of the triangle. 2
23. (a) State Huygens' principle. How did Huygens explain the absence of the backwave ? 2

OR

- (b) Use Huygens' principle to show reflection/refraction of a plane wave by (i) concave mirror, and (ii) a convex lens. 2





24. दो माध्यमों A और B के अपवर्तनांक क्रमशः 2 और $\sqrt{2}$ हैं। इन दोनों के अन्तरापृष्ठ के लिए क्रांतिक कोण क्या है ? 2
25. किसी p-n संधि डायोड का (क) अग्रदिशिक बायसन, और (ख) पश्चदिशिक बायसन में परिपथ आरेख खींचिए। प्रत्येक प्रकरण के लिए V – I अभिलाक्षणिक खींचिए। 2

खण्ड ग

26. (क) किसी आदर्श संधारित्र के सिरो से कोई ac स्रोत $v = v_m \sin \omega t$ संयोजित है। (i) परिपथ में प्रवाहित धारा, और (ii) संधारित्र के प्रतिघात के लिए व्यंजक व्युत्पन्न कीजिए। धारा i और ωt के बीच ग्राफ आलेखित कीजिए। 3

अथवा

- (ख) यदि किसी परिपथ में किसी ac वोल्टता स्रोत के सिरो से श्रेणी में कोई प्रेरक L, संधारित्र C और प्रतिरोधक R संयोजित हैं, तो परिपथ में औसत उपभुक्त शक्ति के लिए व्यंजक प्राप्त कीजिए। (i) परिशुद्ध प्रेरणिक परिपथ, और (ii) परिशुद्ध प्रतिरोधक परिपथ के लिए शक्ति गुणांक ज्ञात कीजिए। 3
27. (क) (i) सिद्ध कीजिए कि सभी नाभिकों के लिए नाभिकीय घनत्व समान होता है।
(ii) किसी न्यूक्लियोनों के युगल के पृथकन को फलन मानकर उस युगल की स्थितिज ऊर्जा का ग्राफ खींचिए। इस ग्राफ से दो निष्कर्ष निकालिए। 3

अथवा

- (ख) (i) गाइगर-मार्सडेन प्रयोग में प्रकीर्णन कोण (θ) को फलन मानकर संसूचित प्रकीर्णित कणों की संख्या (N) के विचरण को दर्शाने के लिए आलेख (ग्राफ) खींचिए।
(ii) इस आलेख से निकाले जाने वाले दो निष्कर्षों की संक्षेप में चर्चा कीजिए और लिखिए कि ये किस प्रकार परमाणु में नाभिक की खोज की ओर ले जाते हैं। 3



24. The refractive indices of two media A and B are 2 and $\sqrt{2}$ respectively. What is the critical angle for their interface? 2
25. Draw a circuit diagram of a p-n junction diode in (a) forward biasing, and (b) reverse biasing. Draw the V – I characteristics for each case. 2

SECTION C

26. (a) An ac source $v = v_m \sin \omega t$ is connected across an ideal capacitor. Derive the expression for the (i) current flowing in the circuit, and (ii) reactance of the capacitor. Plot a graph of current i versus ωt . 3

OR

- (b) A series combination of an inductor L, a capacitor C and a resistor R is connected across an ac source of voltage in a circuit. Obtain an expression for the average power consumed by the circuit. Find power factor for (i) purely inductive circuit, and (ii) purely resistive circuit. 3

27. (a) (i) Prove that the nuclear density is same for all nuclei.
(ii) Draw a plot of potential energy of a pair of nucleons as a function of their separation. Draw two inferences from this plot. 3

OR

- (b) (i) Draw a graph to show the variation of the number of scattered particles detected (N) in Geiger-Marsden experiment as a function of scattering angle (θ).
(ii) Discuss briefly two conclusions that can be drawn from this graph and how they lead to the discovery of nucleus in an atom. 3



28. आरेख में एक आयताकार चालक PQRS दर्शाया गया है जिसकी भुजा PQ की लम्बाई 10 cm और प्रतिरोध 0.4Ω है तथा यह गति करने के लिए स्वतंत्र है। इसे किसी एकसमान चुम्बकीय क्षेत्र $B = 0.2 \text{ T}$, जो PQRS के तल के लम्बवत भीतर की ओर कार्यरत है, में रखा गया है। यदि भुजा PQ को 5 cm/s के वेग v से, दर्शाए अनुसार गति करायी जाए, तो ज्ञात कीजिए :

3

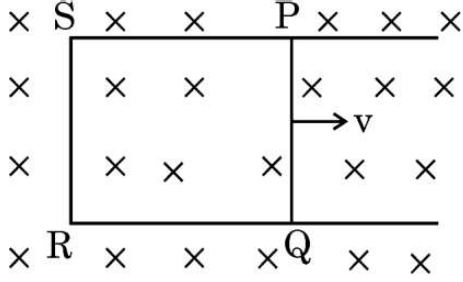

- (क) पाश में प्रेरित विद्युत धारा, तथा
(ख) इस भुजा को गति कराने के लिए आवश्यक शक्ति।
(भुजाओं PS, SR और RQ के प्रतिरोध उपेक्षणीय हैं।)
29. किसी चालक से प्रवाहित धारा और उसके भीतर इलेक्ट्रॉनों के अपवाह वेग के बीच संबंध प्राप्त कीजिए। इस प्रकार ओम का नियम प्राप्त कीजिए।
30. (क) आरेख में दो कर्णों A और B जिन पर समान आवेश हैं परन्तु द्रव्यमान भिन्न हैं, की दे ब्रॉग्ली तरंगदैर्घ्य (λ) को $\frac{1}{\sqrt{V}}$ के फलन के रूप में दर्शाया गया है, जहाँ V वह विभवान्तर है जिससे कर्णों को त्वरित किया गया है।

3

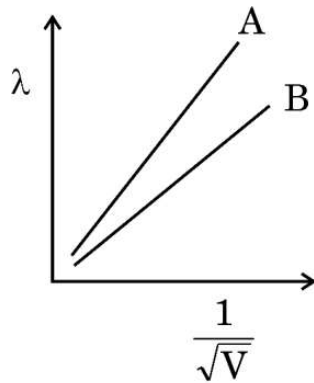

- (i) इन कर्णों में से कौन-सा अधिक भारी है और क्यों ?
(ii) रेखा की प्रवणता क्या निरूपित करती है ?
- (ख) उस इलेक्ट्रॉन का संवेग परिकलित कीजिए जिसकी दे ब्रॉग्ली तरंगदैर्घ्य 3.0 \AA है।

3





28. The figure shows a rectangular conductor PQRS in which the arm PQ of length 10 cm and resistance 0.4Ω is free to move. It is kept in a uniform magnetic field $B = 0.2 \text{ T}$ acting perpendicular into the plane of PQRS. If arm PQ is moved with a velocity v of 5 cm/s as shown, find : 3

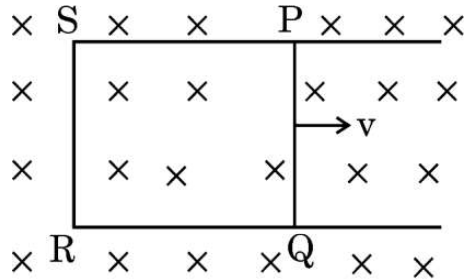

- (a) the current induced in the loop, and
(b) the power required to move the arm.
(Resistances of arms PS, SR and RQ are negligible.)
29. Obtain a relation between the current flowing in a conductor and drift velocity of electrons in it. Hence, obtain Ohm's law. 3

30. (a) The figure shows de Broglie wavelength (λ) for two particles A and B having same charges but different masses as a function of $\frac{1}{\sqrt{V}}$, where V is the potential through which the particles are accelerated.

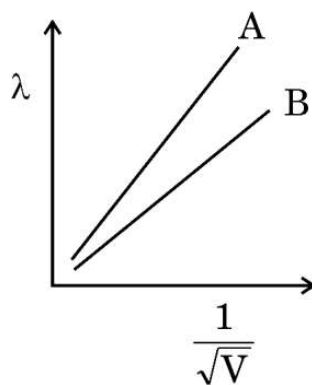

- (i) Which of them is heavier and why ?
(ii) What does the slope of the line represent ?
- (b) Calculate the momentum of an electron having de Broglie wavelength of 3.0 \AA . 3



खण्ड घ

31. (क) (i) वक्रता त्रिज्या 'R' के किसी अवतल दर्पण के सामने दूरी 'u' पर स्थित किसी बिम्ब के वास्तविक प्रतिबिम्ब के बनने को दर्शाने के लिए किरण आरेख खींचिए। इस प्रकार, u और R के पदों में प्रतिबिम्ब दूरी 'v' के लिए संबंध प्राप्त कीजिए।
- (ii) किसी 1 m फोकस दूरी के उत्तल लेंस के सामने 1.8 m लम्बाई का कोई व्यक्ति लेंस से 5 m की दूरी पर खड़ा है। बनने वाले प्रतिबिम्ब की स्थिति और ऊँचाई ज्ञात कीजिए।

5

अथवा

- (ख) (i) किसी त्रिभुजाकार काँच के प्रिज़्म से गुज़रने वाली किसी प्रकाश किरण के अपवर्तन को दर्शाने के लिए किरण आरेख खींचिए। इस प्रकार, अपवर्तनांक (μ) के लिए प्रिज़्म कोण (A) और न्यूनतम विचलन कोण (δ_m) के पदों में संबंध प्राप्त कीजिए।
- (ii) किसी अवतल लेंस के दोनों पृष्ठों की वक्रता त्रिज्याएँ 20 cm हैं। यदि लेंस की क्षमता $-5.0 D$ है, तो लेंस के पदार्थ का अपवर्तनांक ज्ञात कीजिए।

5

32. (क) (i) विद्युत फ्लक्स की परिभाषा दीजिए और इसका SI मात्रक लिखिए।
- (ii) गाउस नियम का उपयोग करके किसी एकसमान रूप से आवेशित अनन्त समतल चादर के कारण विद्युत क्षेत्र के लिए व्यंजक प्राप्त कीजिए।
- (iii) आरेख में दर्शाए अनुसार, भुजा L का कोई घन आकाश (space) में स्थित है। इस प्रदेश में कोई विद्युत क्षेत्र $\vec{E} = (Ax + B) \hat{i} \frac{N}{C}$ विद्यमान है। इस घन के भीतर बन्द नेट आवेश ज्ञात कीजिए।

5

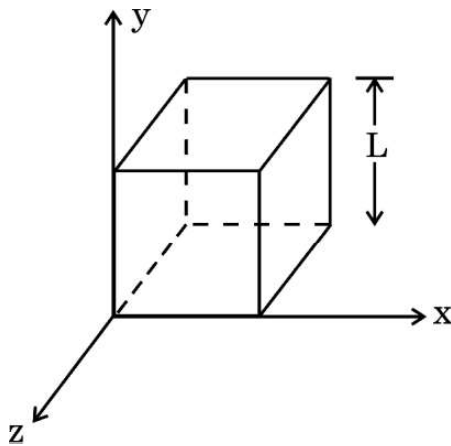

अथवा



SECTION D

31. (a) (i) Draw a ray diagram showing the formation of a real image of an object placed at a distance 'u' in front of a concave mirror of radius of curvature 'R'. Hence, obtain the relation for the image distance 'v' in terms of u and R.
- (ii) A 1.8 m tall person stands in front of a convex lens of focal length 1 m, at a distance of 5 m. Find the position and height of the image formed.

5

OR

- (b) (i) Draw a ray diagram showing refraction of a ray of light through a triangular glass prism. Hence, obtain the relation for the refractive index (μ) in terms of angle of prism (A) and angle of minimum deviation (δ_m).
- (ii) The radii of curvature of the two surfaces of a concave lens are 20 cm each. Find the refractive index of the material of the lens if its power is -5.0 D.

5

32. (a) (i) Define electric flux and write its SI unit.
- (ii) Use Gauss' law to obtain the expression for the electric field due to a uniformly charged infinite plane sheet.
- (iii) A cube of side L is kept in space, as shown in the figure. An electric field $\vec{E} = (Ax + B) \hat{i} + \frac{N}{C}$ exists in the region. Find the net charge enclosed by the cube.

5

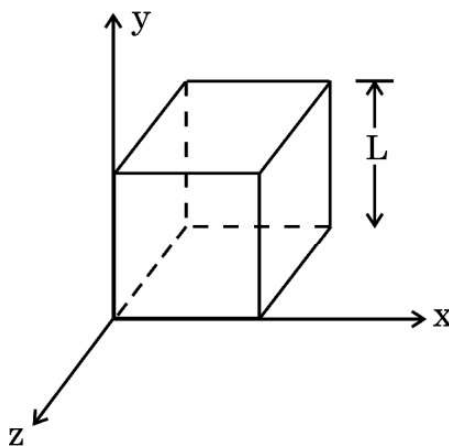

OR



- (ख) (i) किसी बिन्दु पर विद्युत विभव की परिभाषा दीजिए और इसका SI मात्रक लिखिए ।
- (ii) दो संधारित्र श्रेणी में संयोजित हैं । इस संयोजन की तुल्य धारिता के लिए व्यंजक व्युत्पन्न कीजिए ।
- (iii) दो बिन्दु आवेश $+q$ और $-q$, x - y तल में क्रमशः बिन्दुओं $(3a, 0)$ और $(0, 4a)$ पर अवस्थित हैं । मूल-बिन्दु पर कोई तीसरा आवेश Q रखा है । q और a के पदों में Q का वह मान ज्ञात कीजिए जिससे निकाय की स्थिर-वैद्युत स्थितिज ऊर्जा शून्य हो जाए ।

5

33. (क) (i) किसी चल कुण्डली गैल्वैनोमीटर का सिद्धान्त लिखिए और इसकी क्रियाविधि की व्याख्या कीजिए । किसी गैल्वैनोमीटर का, उसके इसी रूप में, किसी परिपथ में धारा मापने के लिए उपयोग नहीं किया जा सकता है । क्यों ?
- (ii) किसी चल कुण्डली गैल्वैनोमीटर में चुम्बकीय क्षेत्र अरीय क्यों बनाते हैं ? इसे किस प्रकार बनाया जाता है ?

5

अथवा

- (ख) (i) किसी धारावाही वृत्ताकार पाश के अक्ष पर चुम्बकीय क्षेत्र के लिए व्यंजक व्युत्पन्न कीजिए ।
- (ii) प्रतिचुम्बकीय पदार्थ और अनुचुम्बकीय पदार्थ के बीच विभेदन करने वाले कोई दो बिन्दु लिखिए ।

5



- (b) (i) Define electric potential at a point and write its SI unit.
- (ii) Two capacitors are connected in series. Derive an expression of the equivalent capacitance of the combination.
- (iii) Two point charges $+q$ and $-q$ are located at points $(3a, 0)$ and $(0, 4a)$ respectively in x - y plane. A third charge Q is kept at the origin. Find the value of Q , in terms of q and a , so that the electrostatic potential energy of the system is zero. 5

- 33.** (a) (i) Write the principle and explain the working of a moving coil galvanometer. A galvanometer as such cannot be used to measure the current in a circuit. Why?
- (ii) Why is the magnetic field made radial in a moving coil galvanometer? How is it achieved? 5

OR

- (b) (i) Derive an expression for magnetic field on the axis of a current carrying circular loop.
- (ii) Write any two points of difference between a diamagnetic and a paramagnetic substance. 5





खण्ड ड

34. आरेख में दर्शाए अनुसार दो पट्टिकाओं के बीच के प्रदेश में कोई इलेक्ट्रॉन पुन्ज क्षैतिजतः 3×10^7 m/s के वेग से गतिमान है। इन पट्टिकाओं के बीच कोई उपयुक्त विभवान्तर अनुप्रयुक्त किया गया है ताकि इलेक्ट्रॉन पुन्ज निचली पट्टिका के किनारे से ठीक-ठीक टकराए।

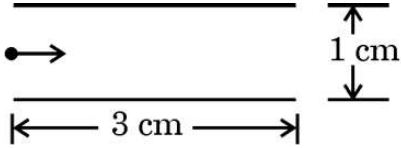

उपर्युक्त के आधार पर निम्नलिखित प्रश्नों के उत्तर दीजिए :

- (क) किनारे से टकराने में कोई इलेक्ट्रॉन कितना समय लेगा ? 1
(ख) इलेक्ट्रॉन के पथ की आकृति क्या है और क्यों ? 1
(ग) अनुप्रयुक्त विभवान्तर ज्ञात कीजिए। 2

अथवा

- (ग) पट्टिकाओं के बीच के प्रदेश में उस चुम्बकीय क्षेत्र के परिमाण और दिशा को ज्ञात कीजिए जिसे इलेक्ट्रॉन पुन्ज को बिना विक्षेपित हुए सीधे जाने के लिए उत्पन्न किया जाना चाहिए। 2

35. किसी वस्तु के कोनों, जिनका आकार प्रकाश की तरंगदैर्घ्य के तुल्य हो, पर प्रकाश तरंग का मुड़ना प्रकाश का विवर्तन कहलाता है। विवर्तन वास्तव में किरण प्रकाशिकी की सीमाएँ परिभाषित करता है। प्रकाशिक यंत्रों के लिए सीमाएँ प्रकाश की तरंगदैर्घ्य द्वारा निर्धारित की जाती हैं। किसी एकल-झिरी के विवर्तन पैटर्न के प्रेक्षण के लिए कोई प्रायोगिक व्यवस्था बनायी जाती है।

उपर्युक्त के आधार पर निम्नलिखित प्रश्नों के उत्तर दीजिए :

- (क) यदि प्रकाश की तरंगदैर्घ्य में वृद्धि कर दी जाए, तो केन्द्रीय उच्चिष्ठ की चौड़ाई किस प्रकार प्रभावित होगी ? 1
(ख) प्रथम निम्निष्ठ प्राप्त करने की क्या शर्त है ? 1
(ग) व्यतिकरण और विवर्तन पैटर्नों के बीच दो अन्तर लिखिए। 2

अथवा

- (ग) दो विद्यार्थी एक 10 m ऊँची कक्ष विभाजक दीवार द्वारा 7 m के अंतर पर हैं। यदि ध्वनि और प्रकाश दोनों प्रकार की तरंगें वस्तु के किनारों पर मुड़ सकती हैं, तो फिर भी वे विद्यार्थी एक-दूसरे को देख नहीं पाते यद्यपि वे आपस में आसानी से वार्तालाप किस प्रकार कर पाते हैं ? 2



SECTION E

34. A beam of electrons moving horizontally with a velocity of 3×10^7 m/s enters a region between two plates as shown in the figure. A suitable potential difference is applied across the plates such that the electron beam just strikes the edge of the lower plate.

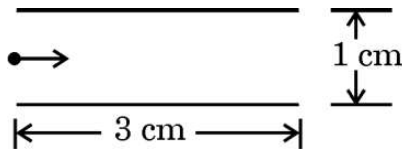

Answer the following questions based on the above :

- (a) How long does an electron take to strike the edge ? 1
- (b) What is the shape of the path followed by the electron and why ? 1
- (c) Find the potential difference applied. 2

OR

- (c) Find the magnitude and direction of the magnetic field which should be created in the space between the plates so that the electron beam goes straight undeviated. 2

35. Diffraction of light is bending of light around the corners of an object whose size is comparable with the wavelength of light. Diffraction actually defines the limits of ray optics. This limit for optical instruments is set by the wavelength of light. An experimental arrangement is set up to observe the diffraction pattern due to a single slit.

Answer the following questions based on the above :

- (a) How will the width of central maximum be affected if the wavelength of light is increased ? 1
- (b) Under what condition is the first minimum obtained ? 1
- (c) Write two points of difference between interference and diffraction patterns. 2

OR

- (c) Two students are separated by a 7 m partition wall in a room 10 m high. If both light and sound waves can bend around obstacles, how is it that the students are unable to see each other even though they can converse easily ? 2

Marking Scheme
Strictly Confidential
(For Internal and Restricted use only)
Senior School Certificate Examination, 2023
SUBJECT NAME PHYSICS (PAPER CODE 55/3/3)

General Instructions: -

1	You are aware that evaluation is the most important process in the actual and correct assessment of the candidates. A small mistake in evaluation may lead to serious problems which may affect the future of the candidates, education system and teaching profession. To avoid mistakes, it is requested that before starting evaluation, you must read and understand the spot evaluation guidelines carefully.
2	“Evaluation policy is a confidential policy as it is related to the confidentiality of the examinations conducted, Evaluation done and several other aspects. Its’ leakage to public in any manner could lead to derailment of the examination system and affect the life and future of millions of candidates. Sharing this policy/document to anyone, publishing in any magazine and printing in News Paper/Website etc may invite action under various rules of the Board and IPC.”
3	Evaluation is to be done as per instructions provided in the Marking Scheme. It should not be done according to one’s own interpretation or any other consideration. Marking Scheme should be strictly adhered to and religiously followed. However, while evaluating, answers which are based on latest information or knowledge and/or are innovative, they may be assessed for their correctness otherwise and due marks be awarded to them. In class-X, while evaluating two competency-based questions, please try to understand given answer and even if reply is not from marking scheme but correct competency is enumerated by the candidate, due marks should be awarded.
4	The Marking scheme carries only suggested value points for the answers These are in the nature of Guidelines only and do not constitute the complete answer. The students can have their own expression and if the expression is correct, the due marks should be awarded accordingly.
5	The Head-Examiner must go through the first five answer books evaluated by each evaluator on the first day, to ensure that evaluation has been carried out as per the instructions given in the Marking Scheme. If there is any variation, the same should be zero after deliberation and discussion. The remaining answer books meant for evaluation shall be given only after ensuring that there is no significant variation in the marking of individual evaluators.
6	Evaluators will mark(√) wherever answer is correct. For wrong answer CROSS ‘X” be marked. Evaluators will not put right (✓) while evaluating which gives an impression that answer is correct and no marks are awarded. This is most common mistake which evaluators are committing.
7	If a question has parts, please award marks on the right-hand side for each part. Marks awarded for different parts of the question should then be totaled up and written in the left-hand margin and encircled. This may be followed strictly.
8	If a question does not have any parts, marks must be awarded in the left-hand margin and encircled. This may also be followed strictly.
9	If a student has attempted an extra question, answer of the question deserving more marks should be retained and the other answer scored out with a note “Extra Question” .
10	No marks to be deducted for the cumulative effect of an error. It should be penalized only once.
11	A full scale of marks 0 - 70 (example 0 to 80/70/60/50/40/30 marks as given in Question Paper) has to be used. Please do not hesitate to award full marks if the answer

	deserves it.
12	Every examiner has to necessarily do evaluation work for full working hours i.e., 8 hours every day and evaluate 20 answer books per day in main subjects and 25 answer books per day in other subjects (Details are given in Spot Guidelines). This is in view of the reduced syllabus and number of questions in question paper.
13	<p>Ensure that you do not make the following common types of errors committed by the Examiner in the past:-</p> <ul style="list-style-type: none"> ● Leaving answer or part thereof unassessed in an answer book. ● Giving more marks for an answer than assigned to it. ● Wrong totaling of marks awarded on an answer. ● Wrong transfer of marks from the inside pages of the answer book to the title page. ● Wrong question wise totaling on the title page. ● Wrong totaling of marks of the two columns on the title page. ● Wrong grand total. ● Marks in words and figures not tallying/not same. ● Wrong transfer of marks from the answer book to online award list. ● Answers marked as correct, but marks not awarded. (Ensure that the right tick mark is correctly and clearly indicated. It should merely be a line. Same is with the X for incorrect answer.) ● Half or a part of answer marked correct and the rest as wrong, but no marks awarded.
14	While evaluating the answer books if the answer is found to be totally incorrect, it should be marked as cross (X) and awarded zero (0) Marks.
15	Any un assessed portion, non-carrying over of marks to the title page, or totaling error detected by the candidate shall damage the prestige of all the personnel engaged in the evaluation work as also of the Board. Hence, in order to uphold the prestige of all concerned, it is again reiterated that the instructions be followed meticulously and judiciously.
16	The Examiners should acquaint themselves with the guidelines given in the “ Guidelines for spot Evaluation ” before starting the actual evaluation.
17	Every Examiner shall also ensure that all the answers are evaluated, marks carried over to the title page, correctly totaled and written in figures and words.
18	The candidates are entitled to obtain photocopy of the Answer Book on request on payment of the prescribed processing fee. All Examiners/Additional Head Examiners/Head Examiners are once again reminded that they must ensure that evaluation is carried out strictly as per value points for each answer as given in the Marking Scheme.



MARKING SCHEME: PHYSICS(042)

Code: 55/3/3

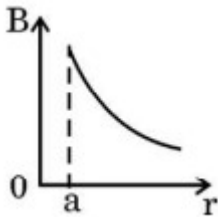
Q.No.	VALUE POINTS/EXPECTED ANSWERS	Marks	Total Marks
SECTION A			
1.	(a) Current in the circuit.	1	1
2.	(c) $\frac{h}{\lambda}$	1	1
3.	(c) $\frac{\mu_0 I^2}{2\pi r}$, attractive	1	1
4.	(d) 8:1	1	1
5.	(a) Only displacement current exists.	1	1
6.	(c) $I \propto A^2$	1	1
7.	(c) Width of depletion layer increases.	1	1
8.	(c) 	1	1
9.	(b) 0.51eV	1	1
10.	(a) $\frac{V_0}{\sqrt{2}}$	1	1
11.	(c) $5 \times 10^9 \text{ m}^{-3}$	1	1
12.	(b) twice	1	1
13.	(b) $\frac{9}{5}$	1	1
14.	(c) $\frac{E}{3}$	1	1
15.	(b) inductor decreases and the capacitor increases.	1	1
16.	(c) Assertion (A) is true but Reason (R) is false	1	1
17.	(d) Assertion (A) is false and Reason (R) is also false	1	1
18.	(a) Both Assertion (A) and Reason(R) are true and Reason (R) is the correct explanation of the Assertion (A).	1	1

	<p>Area of equilateral triangle $= \frac{\sqrt{3}}{4} a^2$</p> $= \frac{\sqrt{3}}{4} \left(\frac{L^2}{9} \right) = \frac{\sqrt{3}L^2}{36}$ <p>Magnetic moment \propto Area of the loop.</p> $\Rightarrow \frac{m_s}{m_t} = \frac{L^2}{16} \times \frac{36}{\sqrt{3}L^2} = \frac{3\sqrt{3}}{4}$	<p>$\frac{1}{2}$</p> <p>$\frac{1}{2}$</p> <p>$\frac{1}{2}$</p>	<p>2</p>				
23.	<p>(a)</p> <table border="1" style="width: 100%;"> <tr> <td>Statement of Huygen's Principle</td> <td style="text-align: right;">1</td> </tr> <tr> <td>Explanation</td> <td style="text-align: right;">1</td> </tr> </table> <p>Statement: Each point of the wavefront is the source of secondary disturbance in all directions.</p> <p>Common tangent to all the secondary wavelets gives new position of the wavefront.</p> <p>Explanation: Light energy cannot travel in backward direction.</p> <p>Alternatively: It was an adhoc assumption .</p> <p>Alternatively: For back wave: $I = \frac{1}{2} (1 + \cos \theta)$ at $\theta = 180^\circ$; contribution is zero.</p> <p>Alternatively: Amplitude of secondary wavelets is maximum in forward direction and zero in backward in direction.</p> <p>Note: If any other relevant explanation given, give full credit.</p>	Statement of Huygen's Principle	1	Explanation	1	<p>$\frac{1}{2}$</p> <p>$\frac{1}{2}$</p> <p>1</p>	
Statement of Huygen's Principle	1						
Explanation	1						
	<p style="text-align: center;">OR</p> <p>(b)</p> <table border="1" style="width: 100%;"> <tr> <td>(i) Diagram for concave mirror</td> <td style="text-align: right;">1</td> </tr> <tr> <td>(ii) Diagram for convex lens</td> <td style="text-align: right;">1</td> </tr> </table>	(i) Diagram for concave mirror	1	(ii) Diagram for convex lens	1		
(i) Diagram for concave mirror	1						
(ii) Diagram for convex lens	1						

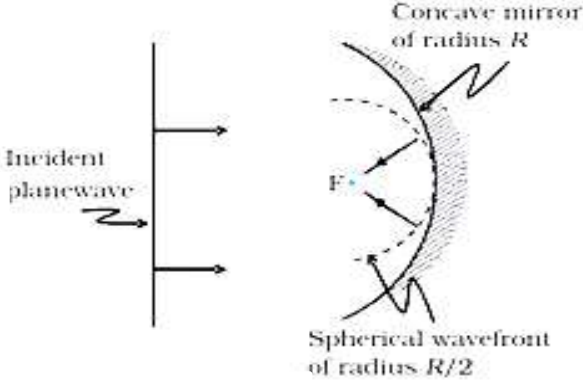
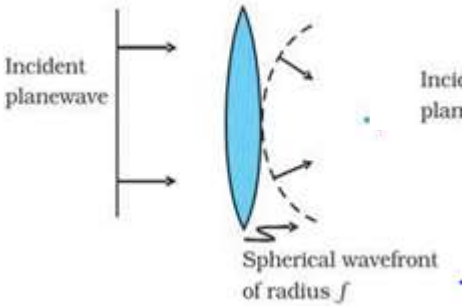
	<p>(i)</p>  <p>(ii)</p> 	1	1		
24.	<table border="1" data-bbox="298 1117 1304 1207"> <tr> <td>Calculation of critical angle</td> <td>2</td> </tr> </table> <p>From Snell 's law:- $\mu_A \sin i_c = \mu_B \sin 90^\circ$ $2 \times \sin i_c = \sqrt{2} \times 1$ $\sin i_c = \frac{1}{\sqrt{2}}$ $i_c = 45^\circ$</p>	Calculation of critical angle	2	1/2	2
Calculation of critical angle	2				
	<p>Alternatively: $\sin i_c = \frac{1}{\mu_B \mu_A}$ $\sin i_c = \frac{1}{\sqrt{2}}$ $i_c = 45^\circ$</p>	1	2		

25.

Circuit Diagram	
(a) Forward Biasing	$\frac{1}{2}$
(b) Reverse Biasing	$\frac{1}{2}$
VI characteristics for each case	$\frac{1}{2} + \frac{1}{2}$

(a) Forward Bias

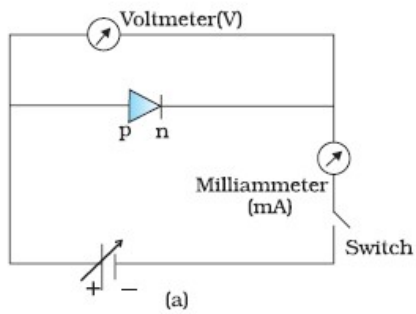

$\frac{1}{2}$

(b) Reverse Bias

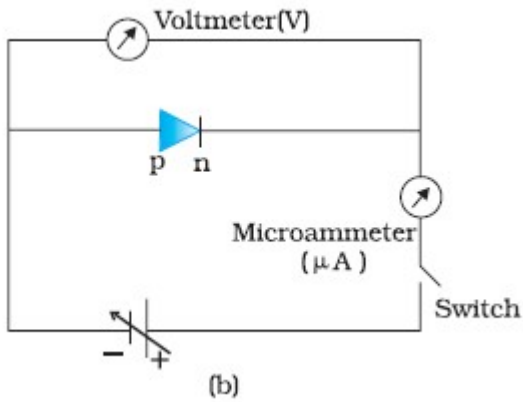

$\frac{1}{2}$

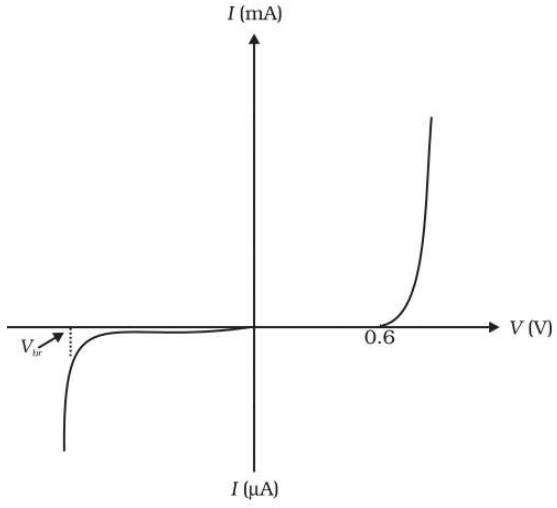
	<p>VI Characteristics</p> 	<p>$\frac{1}{2} + \frac{1}{2}$</p>	<p>2</p>						
SECTION C									
<p>26.</p>	<p>(a)</p> <table border="1" data-bbox="298 936 1304 1056"> <tr> <td>(i) Expression for current</td> <td>1</td> </tr> <tr> <td>(ii) Reactance of the capacitor</td> <td>1</td> </tr> <tr> <td>Graph of i versus ωt</td> <td>1</td> </tr> </table> <p>(i) $V_m \sin \omega t = \frac{q}{C}$</p> $I = \frac{dq}{dt} = \frac{d}{dt}(CV_m \sin \omega t)$ $I = \omega CV_m \cos \omega t$ <p>Alternatively:-</p> $I = \frac{V_m}{\frac{1}{\omega C}} \cos \omega t = I_m \sin(\omega t + \frac{\pi}{2})$ <p>(ii) $I = \frac{V_m}{\frac{1}{\omega C}} \sin(\omega t + \frac{\pi}{2}) = I_m \sin(\omega t + \frac{\pi}{2})$</p> <p>Comparing with $I_m = \frac{V_m}{\frac{1}{\omega C}}$</p> <p>Reactance of the capacitor; $X_c = \frac{1}{\omega C}$</p>	(i) Expression for current	1	(ii) Reactance of the capacitor	1	Graph of i versus ωt	1	<p>$\frac{1}{2}$</p> <p>$\frac{1}{2}$</p> <p>1</p>	
(i) Expression for current	1								
(ii) Reactance of the capacitor	1								
Graph of i versus ωt	1								

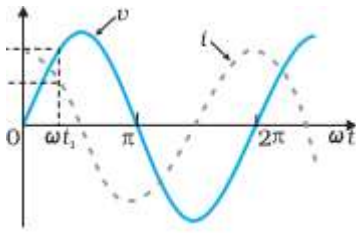

OR

(b)

Expression for average power consumed	2
Power Factor for	
(i) Purely Inductive circuit	$\frac{1}{2}$
(ii) Purely Resistive Circuit	$\frac{1}{2}$

Instantaneous Power;

$$P = VI = (V_m \sin \omega t) \times i_m \sin(\omega t + \phi)$$

$\frac{1}{2}$

$$P = \frac{V_m i_m}{2} [\cos \phi - \cos(2\omega t + \phi)] \quad \text{----(1)}$$

$\frac{1}{2}$

The average power over a cycle is given by the average of the two terms in the R.H.S of equation (1). It is only the second term which is time dependent .Its average is zero (the positive half of the cosine cancels the negative half).

$\frac{1}{2}$

Therefore,

$$P_{avg} = \frac{V_m I_m}{2} \cos \phi = \frac{V_m}{\sqrt{2}} \frac{I_m}{\sqrt{2}} \cos \phi$$

$\frac{1}{2}$

$$P_{avg} = V_{rms} I_{rms} \cos \phi$$

Alternatively:-

If the expression is deduced using integration, then full credit to be given.

(i) Power factor for purely inductive circuit, $\phi = \frac{\pi}{2} \Rightarrow \cos \phi = 0$

$\frac{1}{2}$

(ii) Power factor for purely resistive circuit; $\phi = 0 \Rightarrow \cos \phi = 1$

$\frac{1}{2}$

3

27.

(a)

(i) Prove that nuclear density is constant	1
(ii) Graph between potential energy & separation Two Inferences	1 $\frac{1}{2} + \frac{1}{2}$

(i) $\rho = \frac{\text{mass}}{\text{volume}}$

$= \frac{\text{mass number} \times \text{mass of nucleon}}{\text{volume of nucleus}}$

$\rho = \frac{A \times m}{\frac{4}{3}\pi(R_0 A^{1/3})^3} = \frac{3m}{4\pi R_0^3}$

Hence, density is independent of mass number.

(ii)

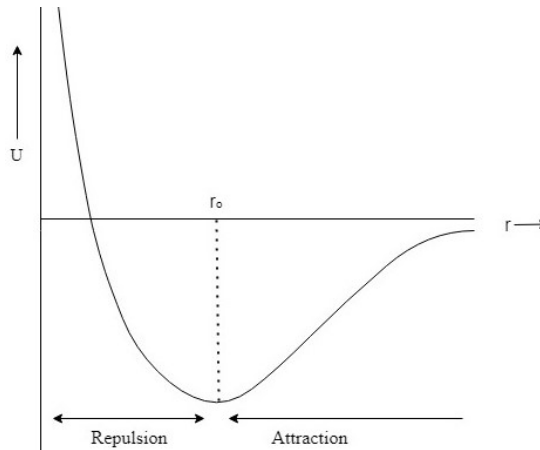

Inferences

- The force is attractive for distances larger than r_0 .
- The force is repulsive for distance less than r_0 .

Alternatively:-

Any other relevant inference drawn from the graph should be given full credit.

OR

(b)

(i) Graph to show the variation of the number of scattered particles as a function of scattering angle.	1
(ii) Two conclusions Discovery of nucleus	$\frac{1}{2} + \frac{1}{2}$ 1

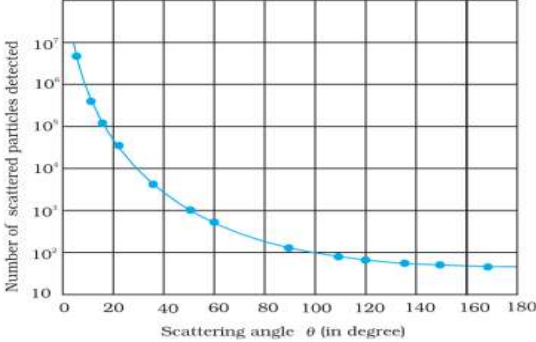
	<p>(i)</p>  <p>(ii)- The entire positive charge and most of the mass of the atom are concentrated in a small space. -Many of the α-particles pass through the foil. It means that they do not suffer any collisions.</p> <p>To deflect the α-particle backwards, a large repulsive force is required, which is provided only if the greater part of the mass of the atom & its positive charge were concentrated tightly at its centre. This led to the discovery of the nucleus in the atom.</p>	<p>1</p> <p>$\frac{1}{2}$</p> <p>$\frac{1}{2}$</p> <p>1</p>	<p>3</p>						
<p>28.</p>	<table border="1" data-bbox="298 1180 1302 1293"> <tr> <td>Finding the</td> <td></td> </tr> <tr> <td>(a) Current induced</td> <td>$1\frac{1}{2}$</td> </tr> <tr> <td>(b) Power required</td> <td>$1\frac{1}{2}$</td> </tr> </table> <p>(a)</p> $i = \frac{Blv}{R}$ $= \frac{0.2 \times (10 \times 10^{-2}) \times (5 \times 10^{-2})}{0.4}$ $i = 2.5 \times 10^{-3} A$ <p>(b)</p> $P = i^2 R$ $= (2.5 \times 10^{-3})^2 \times 0.4$ $P = 2.5 \times 10^{-6} W$	Finding the		(a) Current induced	$1\frac{1}{2}$	(b) Power required	$1\frac{1}{2}$	<p>$\frac{1}{2}$</p> <p>$\frac{1}{2}$</p> <p>$\frac{1}{2}$</p> <p>$\frac{1}{2}$</p> <p>$\frac{1}{2}$</p> <p>$\frac{1}{2}$</p>	<p>3</p>
Finding the									
(a) Current induced	$1\frac{1}{2}$								
(b) Power required	$1\frac{1}{2}$								

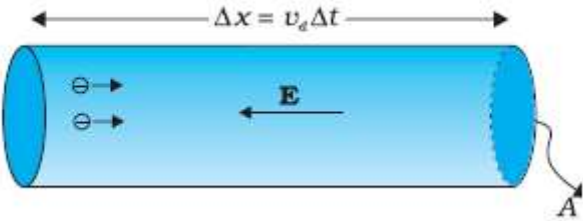
<p>29.</p>	<table border="1" style="width: 100%; border-collapse: collapse;"> <tr> <td style="padding: 5px;">Obtaining relation between current and drift velocity</td> <td style="text-align: right; padding: 5px;">1½</td> </tr> <tr> <td style="padding: 5px;">Deduction of Ohm's Law</td> <td style="text-align: right; padding: 5px;">1½</td> </tr> </table> <div style="text-align: center; margin: 10px 0;">  </div> <p>Volume of the wire = Al No. of e^- in this volume = nAl Charge on the conductor = $(nAl)e$ The amount of charge crossing the area A in time Δt is $I\Delta t$; where I is the magnitude of the current. Hence,</p> $I\Delta t = +neA v_d \Delta t$ $\Rightarrow I = neAv_d$ <p>Since $v_d = \frac{eE}{m}\tau$</p> $I = neA\left(\frac{e\tau}{m}\right)\frac{V}{l} = \left(\frac{ne^2\tau}{m}\right)A\left(\frac{V}{l}\right)$ $\Rightarrow \frac{V}{I} = \left(\frac{m}{ne^2\tau}\right)\frac{l}{A}$ <p>Hence $\frac{V}{I}$ is constant for a given conductor at constant temperature. $\Rightarrow V \propto I$</p>	Obtaining relation between current and drift velocity	1½	Deduction of Ohm's Law	1½	<p>½</p> <p>½</p> <p>½</p> <p>½</p>	<p>3</p>		
Obtaining relation between current and drift velocity	1½								
Deduction of Ohm's Law	1½								
<p>30.</p>	<table border="1" style="width: 100%; border-collapse: collapse;"> <tr> <td style="padding: 5px;">(a) (i) Identification of heavier mass & reason</td> <td style="text-align: right; padding: 5px;">½ + ½</td> </tr> <tr> <td style="padding: 5px;"> (ii) Slope of line</td> <td style="text-align: right; padding: 5px;">1</td> </tr> <tr> <td style="padding: 5px;">(b) Calculation of momentum</td> <td style="text-align: right; padding: 5px;">1</td> </tr> </table> <p>(a)(i) B is heavier than A Reason- Slope $\propto \frac{1}{\sqrt{m}}$</p>	(a) (i) Identification of heavier mass & reason	½ + ½	(ii) Slope of line	1	(b) Calculation of momentum	1	<p>½</p> <p>½</p>	
(a) (i) Identification of heavier mass & reason	½ + ½								
(ii) Slope of line	1								
(b) Calculation of momentum	1								

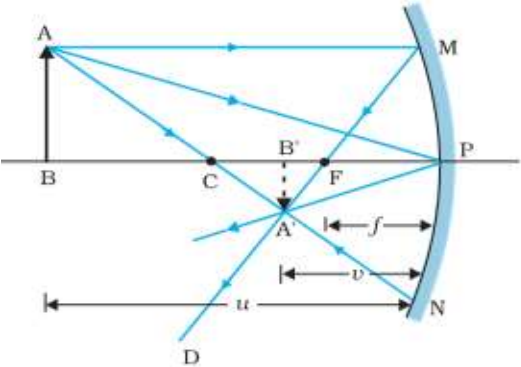
	<p>Slope of A > slope of B;</p> <p>Hence $m_B > m_A$</p> <p>(ii) $\lambda = \frac{h}{\sqrt{2mqV}}$</p> <p>$\lambda = \frac{h}{\sqrt{2mq}} \times \frac{1}{\sqrt{V}}$</p> <p>So, slope = $\frac{h}{\sqrt{2mq}}$</p> <p>(b) Momentum, $p = \frac{h}{\lambda}$</p> <p>$= \frac{6.63 \times 10^{-34}}{3 \times 10^{-10}}$</p> <p>$p = 2.21 \times 10^{-24} \text{ kgm/s}$</p>	<p>$\frac{1}{2}$</p> <p>$\frac{1}{2}$</p> <p>$\frac{1}{2}$</p> <p>$\frac{1}{2}$</p>	<p>3</p>								
SECTION D											
<p>31.</p>	<p>(a)</p> <table border="1" data-bbox="298 1073 1302 1224"> <tr> <td>(i) Ray diagram showing formation of real image in a concave mirror.</td> <td>1</td> </tr> <tr> <td>Obtaining the relation between u,v and R</td> <td>2</td> </tr> <tr> <td>(ii) Position of image formed</td> <td>1</td> </tr> <tr> <td>Height of image formed</td> <td>1</td> </tr> </table> <p>(i)</p>  <p>From Fig. the two right-angled triangles A'B'F and MPF are similar. (For paraxial rays, MP can be considered to be a straight line perpendicular to CP.) Therefore,</p>	(i) Ray diagram showing formation of real image in a concave mirror.	1	Obtaining the relation between u,v and R	2	(ii) Position of image formed	1	Height of image formed	1	<p>1</p>	
(i) Ray diagram showing formation of real image in a concave mirror.	1										
Obtaining the relation between u,v and R	2										
(ii) Position of image formed	1										
Height of image formed	1										

	$\frac{B'A'}{PM} = \frac{B'F}{FP}$ $\text{or } \frac{B'A'}{BA} = \frac{B'F}{FP} \quad (\because PM = AB) \quad \text{-----(i)}$ <p>Since $\angle APB = \angle A'PB'$, the right angled triangles $A'B'P$ and ABP are also similar. Therefore,</p> $\frac{B'A'}{BA} = \frac{B'P}{BP} \quad \text{----(ii)}$ <p>Comparing equations (i) and (ii)</p> $\frac{B'F}{FP} = \frac{B'P - FP}{FP} = \frac{B'P}{BP} \quad \text{-----(iii)}$ <p>$B'P = -v$, $FP = -f$, $BP = -u$;</p> <p>Using these in Eq.(iii) we get $\frac{1}{v} + \frac{1}{u} = \frac{1}{f} = \frac{2}{R}$</p> <p>Alternatively:- If the result derived by any other method, full credit to be given.</p> <p>(ii) For lens: $\frac{1}{v} - \frac{1}{u} = \frac{1}{f}$</p> <p>$u = -5m$; $f = +1m$</p> $\frac{1}{v} - \frac{1}{-5} = \frac{1}{(+1)}$ $\Rightarrow v = \frac{5}{4}m = 1.25m$ $m = \frac{I}{O} = \frac{v}{u} = \frac{(+5/4)}{(-5)}$ <p>$I = (-0.25) \times (1.8)$ $I = -0.45 \text{ m}$</p>	<p>$\frac{1}{2}$</p> <p>$\frac{1}{2}$</p> <p>$\frac{1}{2}$</p> <p>$\frac{1}{2}$</p> <p>$\frac{1}{2}$</p> <p>$\frac{1}{2}$</p> <p>$\frac{1}{2}$</p>	
--	---	---	--

OR

(b)

(i) Ray diagram showing refraction of a ray of light through a rectangular glass prism.	1
Obtaining the relation between μ, A & δ_m	2
(ii) Finding Refractive Index of material of the lens.	2

(i)

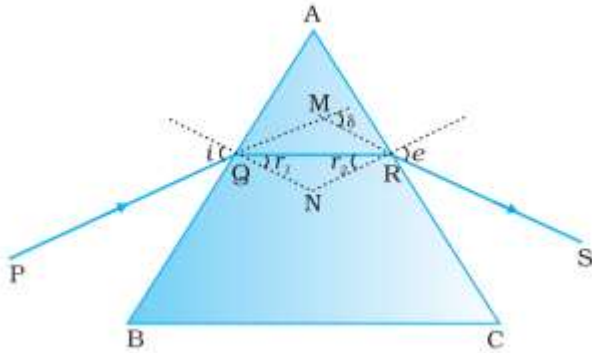

In the quadrilateral AQNR, two of the angles (at the vertices Q and R) are right angles. Therefore, the sum of the other angles of the quadrilateral is 180° .

$$\angle A + \angle QNR = 180^\circ$$

$$\text{From the triangle QNR, } r_1 + r_2 + \angle QNR = 180^\circ$$

Comparing these two equations, we get

$$r_1 + r_2 = A \quad \text{-----(i)}$$

The total deviation δ is the sum of deviations at the two faces,

$$\delta = (i - r_1) + (e - r_2) \text{ that is, } \delta = i + e - A \quad \text{-----(ii)}$$

When $\delta = \delta_m$; $i = e$ & $r_1 = r_2$

$$\text{From (i); } 2r = A \text{ or } r = A/2$$

$$\text{From (ii); } \delta_m = 2i - A \text{ or } i = \frac{A + \delta_m}{2}$$

$$\mu = \frac{\sin i}{\sin r} = \frac{\sin\left(\frac{A + \delta_m}{2}\right)}{\sin\frac{A}{2}}$$

(ii) Given; $P = -5D$

$$f \text{ (in cm)} = \frac{100}{(-5)} = -20 \text{ cm}$$

$$\text{Using Lens Maker's formula ; } \frac{1}{f} = (\mu - 1) \left[\frac{1}{R_1} - \frac{1}{R_2} \right]$$

$$\frac{1}{(-20)} = (\mu - 1) \left[\frac{1}{(-20)} - \frac{1}{(+20)} \right]$$

1

$\frac{1}{2}$

$\frac{1}{2}$

$\frac{1}{2}$

$\frac{1}{2}$

$\frac{1}{2}$

$\frac{1}{2}$

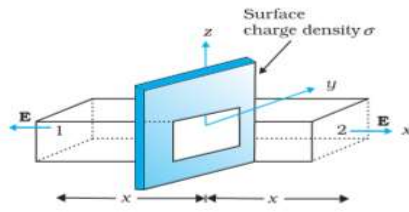
	$\frac{1}{(-20)} = (\mu - 1) \left[-\frac{1}{10} \right]; \quad \mu - 1 = \frac{1}{2}$ $\Rightarrow \mu = \frac{3}{2} = 1.5$	$\frac{1}{2}$ $\frac{1}{2}$	5						
32.	<p>(a)</p> <table border="1"> <tr> <td>(i) Definition & SI Unit of Electric Flux</td> <td>$\frac{1}{2} + \frac{1}{2}$</td> </tr> <tr> <td>(ii) Deriving the expression for electric field due to a uniformly charged infinite plane sheet.</td> <td>2</td> </tr> <tr> <td>(iii) Net charge enclosed by the cube</td> <td>2</td> </tr> </table> <p>(i) $\phi = \vec{E} \cdot \vec{A}$ Alternatively: Electric flux is the number of electric field lines passing through an area normally. S.I. unit of electric flux Nm^2/C or $\text{V}\cdot\text{m}$.</p> <p>(ii)</p>  <p>From Gauss's law:- $\phi = \oint \vec{E} \cdot d\vec{A} = \frac{q}{\epsilon_0}$</p> $2EA = \frac{\sigma A}{\epsilon_0}$ $E = \frac{\sigma}{2\epsilon_0}$ <p>Alternatively: If the shape of the Gaussian surface is taken cylindrical, full credit to be given.</p>	(i) Definition & SI Unit of Electric Flux	$\frac{1}{2} + \frac{1}{2}$	(ii) Deriving the expression for electric field due to a uniformly charged infinite plane sheet.	2	(iii) Net charge enclosed by the cube	2	$\frac{1}{2}$ $\frac{1}{2}$ $\frac{1}{2}$ $\frac{1}{2}$ $\frac{1}{2}$	
(i) Definition & SI Unit of Electric Flux	$\frac{1}{2} + \frac{1}{2}$								
(ii) Deriving the expression for electric field due to a uniformly charged infinite plane sheet.	2								
(iii) Net charge enclosed by the cube	2								

(iii)

$$\phi_L = E ds \cos 180^\circ = -E ds$$

$$= -BL^2$$

$$\phi_R = E ds \cos 0^\circ = E ds$$

$$= (AL + B)L^2 = AL^3 + BL^2$$

$$\text{Net flux} = \phi_L + \phi_R$$

$$= (AL^3 + BL^2) - BL^2$$

$$\text{Net flux} = AL^3 = \frac{q}{\epsilon_0}$$

$$\Rightarrow q = AL^3 \epsilon_0$$

1/2

1/2

1/2

1/2

OR

(b)

(i) Definitions & S.I. Unit of electric potential	1/2 + 1/2
(ii) Derivation of expression of Equivalent capacitance	2
(iii) Calculation of Electrostatic Potential Energy	2

(i) Electrical Potential – Electrostatic potential at any point in a region with electrostatic field is the work done in bringing a unit positive charge (without acceleration) from infinity to that point.

1/2

Alternatively:-

$$V = \frac{\text{Work Done}}{q}$$

$$V = -\int \vec{E} \cdot \vec{dl}$$

S.I. unit of electrostatic potential is volt.

1/2

Alternatively:-



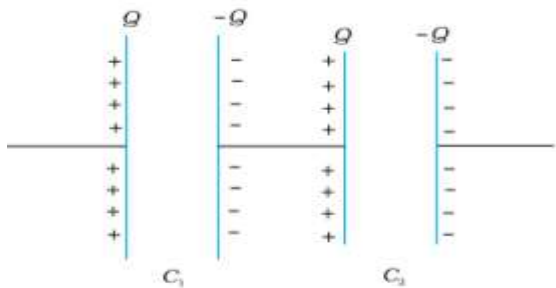



S.I. unit is J/C.

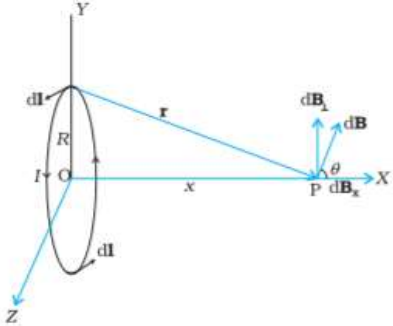

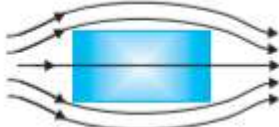
1/2

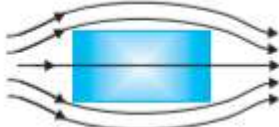
	$V = V_1 + V_2 = \frac{Q}{C_1} + \frac{Q}{C_2}$ $\frac{Q}{C_{eq.}} = Q \left(\frac{1}{C_1} + \frac{1}{C_2} \right)$ $\frac{1}{C_{eq.}} = \frac{1}{C_1} + \frac{1}{C_2}$ <p>(iii)</p> <p>Potential energy of the system = $K \left[\frac{Q(-q)}{4a} + \frac{Qq}{3a} - \frac{q^2}{5a} \right]$</p> <p>Potential energy of the system = 0</p> $\Rightarrow K \left[\frac{-Qq}{4a} + \frac{Qq}{3a} - \frac{q^2}{5a} \right] = 0$ $\Rightarrow \frac{-Q}{4} + \frac{Q}{3} - \frac{q}{5} = 0$ $\Rightarrow +\frac{Q}{12} - \frac{q}{5} = 0$ $\Rightarrow Q = + \frac{12q}{5}$	<p>1/2</p> <p>1/2</p> <p>1/2</p> <p>1/2</p> <p>1</p>	<p>5</p>												
<p>33.</p>	<p>(a)</p> <table border="1" data-bbox="298 1115 1300 1341"> <tr> <td>(i) For a moving coil galvanometer</td> <td></td> </tr> <tr> <td>Principle</td> <td>1</td> </tr> <tr> <td>Working</td> <td>1</td> </tr> <tr> <td>Reason it cannot be used as such</td> <td>1</td> </tr> <tr> <td>(ii) Reason for radial field</td> <td>1</td> </tr> <tr> <td>How radial field is achieved</td> <td>1</td> </tr> </table> <p>(i) Principle – When a rectangular loop carrying current I is placed in a uniform magnetic field, it experiences a torque.</p> <p>Working:- When a current flows through the coil of a galvanometer, a torque acts on it. $\tau = NiAB \sin \theta$ For radial magnetic field; $\sin \theta = 1$ The spring provides a counter or restoring torque $k\phi$. $k\phi = NiAB$</p> <p>In equilibrium; $\phi = \left(\frac{NAB}{k} \right) i$</p> <p>Galvanometer cannot be used as such to measure current because: -It has large resistance and hence will change the value of current in the</p>	(i) For a moving coil galvanometer		Principle	1	Working	1	Reason it cannot be used as such	1	(ii) Reason for radial field	1	How radial field is achieved	1	<p>1</p> <p>1</p>	
(i) For a moving coil galvanometer															
Principle	1														
Working	1														
Reason it cannot be used as such	1														
(ii) Reason for radial field	1														
How radial field is achieved	1														

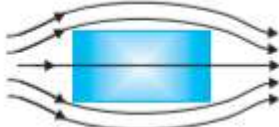
	<p>circuit. -It is a sensitive device. (Any one of the above)</p> <p>(ii) The magnetic field is made radial in a moving coil galvanometer so that the magnetic dipole moment (\vec{m}) is always perpendicular to the magnetic field (\vec{B}) Hence, $\sin \theta = 1$ always Alternatively: The magnetic field is made radial in a moving coil galvanometer to make the scale linear.</p> <p>It is achieved by using curved magnetic poles.</p> <p>Alternatively:-By using soft iron cylindrical core.</p> <p style="text-align: center;">OR</p> <p>(b)</p> <table border="1" style="width: 100%; border-collapse: collapse;"> <tr> <td style="padding: 5px;">(i) Derivation of expression for magnetic field on the axis of a current carrying loop.</td> <td style="text-align: right; padding: 5px;">3</td> </tr> <tr> <td style="padding: 5px;">(ii) Two differences between diamagnetic and paramagnetic substance.</td> <td style="text-align: right; padding: 5px;">1+1</td> </tr> </table> <p>(i)</p>  $dB = \frac{\mu_0}{4\pi} \frac{I d\vec{l} \times \vec{r} }{r^3}$ $= \frac{\mu_0 i dl \sin 90^\circ}{4\pi(x^2 + R^2)}$ <p>dB_{\perp} cancels out.</p> <p>Net B = $\int dB_x = \int dB \cos \theta$</p>	(i) Derivation of expression for magnetic field on the axis of a current carrying loop.	3	(ii) Two differences between diamagnetic and paramagnetic substance.	1+1	<p>1</p> <p>1</p> <p>1</p> <p>3</p> <p>1+1</p> <p>1/2</p> <p>1/2</p> <p>1/2</p> <p>1/2</p>	
(i) Derivation of expression for magnetic field on the axis of a current carrying loop.	3						
(ii) Two differences between diamagnetic and paramagnetic substance.	1+1						

	$= \frac{\mu_o}{4\pi} \int \frac{idl}{(x^2 + R^2)} \times \frac{R}{(x^2 + R^2)^{1/2}}$ $= \frac{\mu_o iR}{4\pi(x^2 + R^2)^{3/2}} \int dl$ $= \frac{\mu_o iR}{4\pi(x^2 + R^2)^{3/2}} (2\pi R)$ $\mathbf{B} = B_x \hat{\mathbf{i}} = \frac{\mu_o I R^2}{2(x^2 + R^2)^{3/2}} \hat{\mathbf{i}}$ <p>(ii) Differences</p> <table border="1" data-bbox="300 898 1302 1528"> <tr> <td data-bbox="300 898 800 1528"> <p>Diamagnetic Materials</p> <p>(i) Susceptibility is between -1 and 0.</p> <p>(ii) Relative permeability is between 0 and 1.</p> <p>(iii) $\mu < \mu_o$</p> <p>(iv) Tendency to move from stronger to weaker part of external magnetism.</p> <p>(v) is repelled by a magnet.</p> <p>(vi) Field inside the material is reduced.</p> <p>(vii)</p>  </td> <td data-bbox="800 898 1302 1528"> <p>Paramagnetic Materials</p> <p>(i) Susceptibility is a small positive number.(slightly greater than zero.)</p> <p>(ii) Relative permeability is slightly greater than 1.</p> <p>(iii) $\mu > \mu_o$</p> <p>(iv) Tendency to move from region of weak to strong magnetic field.</p> <p>(v) is weakly attracted by a magnet.</p> <p>(vi) Field inside is slightly enhanced.</p> <p>(vii)</p>  </td> </tr> </table> <p>Any two of the above mentioned differences.</p>	<p>Diamagnetic Materials</p> <p>(i) Susceptibility is between -1 and 0.</p> <p>(ii) Relative permeability is between 0 and 1.</p> <p>(iii) $\mu < \mu_o$</p> <p>(iv) Tendency to move from stronger to weaker part of external magnetism.</p> <p>(v) is repelled by a magnet.</p> <p>(vi) Field inside the material is reduced.</p> <p>(vii)</p> 	<p>Paramagnetic Materials</p> <p>(i) Susceptibility is a small positive number.(slightly greater than zero.)</p> <p>(ii) Relative permeability is slightly greater than 1.</p> <p>(iii) $\mu > \mu_o$</p> <p>(iv) Tendency to move from region of weak to strong magnetic field.</p> <p>(v) is weakly attracted by a magnet.</p> <p>(vi) Field inside is slightly enhanced.</p> <p>(vii)</p> 	<p>1/2</p> <p>1/2</p> <p>1+1</p> <p>5</p>	
<p>Diamagnetic Materials</p> <p>(i) Susceptibility is between -1 and 0.</p> <p>(ii) Relative permeability is between 0 and 1.</p> <p>(iii) $\mu < \mu_o$</p> <p>(iv) Tendency to move from stronger to weaker part of external magnetism.</p> <p>(v) is repelled by a magnet.</p> <p>(vi) Field inside the material is reduced.</p> <p>(vii)</p> 	<p>Paramagnetic Materials</p> <p>(i) Susceptibility is a small positive number.(slightly greater than zero.)</p> <p>(ii) Relative permeability is slightly greater than 1.</p> <p>(iii) $\mu > \mu_o$</p> <p>(iv) Tendency to move from region of weak to strong magnetic field.</p> <p>(v) is weakly attracted by a magnet.</p> <p>(vi) Field inside is slightly enhanced.</p> <p>(vii)</p> 				

	<p>Any two of the above differences.</p> <p style="text-align: center;">OR</p> <p>(c) The opening (slit) is 3m; which is of the order of the wavelength of sound waves whereas it is very large compare to the wavelength of light. Hence, sound can bend around the obstacle while light cannot.</p>	2	4
--	--	---	---